

# INTREPID™

## SOFTWARE DEVELOPMENT KITS (SDK)

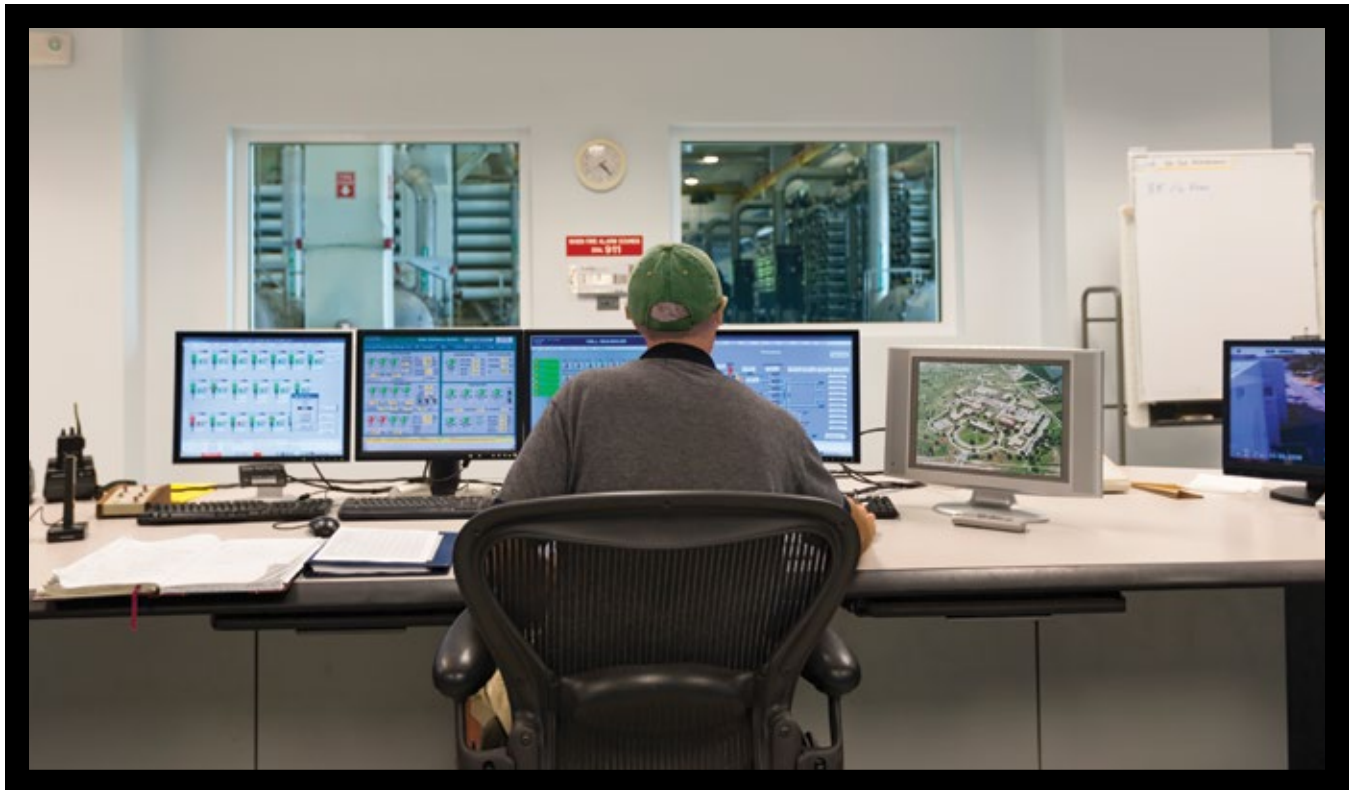

INTREPID™ Polling Protocol II (IPP II)



Remote Polling Module II (RPM II)

Southwest Microwave is committed to providing perimeter security solutions that will integrate seamlessly into our customers' overall security programs. We offer Software Development Kit (SDK) documentation to developers and systems integrators for INTREPID™ Series II perimeter intrusion detection systems (MicroPoint™ II, MicroTrack™ II, MicroWave 330) enabling discovery, monitoring, command and control of these technologies through new or existing physical security information management (PSIM) systems, assessment technologies (CCTV / DVR) and other custom control applications.

Southwest Microwave's SDK toolkits achieve a range of control and monitoring functionality\* for the INTREPID™ sensor suite and auxiliary inputs, including:

- Real-time notification of intrusion attempts, tamper and service alarms
- Monitoring of auxiliary inputs on all INTREPID™ devices for alarm and tamper conditions
- Tie-in of camera setting and position presets to fence, buried cable and microwave detection zones
- Visual assessment of intrusion attempts or tampering
- Storage of intrusion and tamper events in alarm history

With TCP/IP networks commonly used as a base for security and surveillance command and control applications, these SDK resources allow plug-and-play deployment of Southwest Microwave's INTREPID™ perimeter security solutions into today's network infrastructure.\*\*

\* Functionality is developer-dependent.

\*\* RPM II SDK offers direct TCP/IP network access. IPP II SDK requires external network device for TCP/IP access.

# FLEXIBLE SDK OPTIONS

Two INTREPID™ SDK toolkits facilitate the development of high-level interface between INTREPID™ Series II perimeter intrusion detection solutions and third-party PSIM, surveillance systems or other custom control applications:



## INTREPID™ POLLING PROTOCOL II (IPP II) SDK

Part #57A46504-A01

The INTREPID™ Polling Protocol II (IPP II) Software Development Kit (SDK) is an application layer protocol developed by Southwest Microwave that provides a method for a third-party control or monitoring system to query status and send commands between individual INTREPID™ Series II sensors and auxiliary devices, which include:

MicroPoint™ II - Processor Module II (PM II)  
MicroTrack™ II - MicroTrack™ Processor II (MTP II)  
MicroWave 330  
Alarm Input Module II (AIM II)  
Relay Output Module II (ROM II)

The IPP II protocol uses a packet/frame format to send/receive messages between a master and a slave. This standard is specific to serial line communications.

With the IPP II SDK, each INTREPID™ module is queried individually by the third-party control or monitoring application.



## REMOTE POLLING MODULE II (RPM II) SDK

Part #57A46792-A01

The Remote Polling Module II (RPM II) SDK is an application layer protocol / hardware combination that provides a method for third-party control or monitoring systems to interface with INTREPID™ Series II sensors and auxiliary devices through the INTREPID™ Remote Polling Module II (RPM II) via TCP/IP socket layer. This standard is specific to TCP/IP IPv4 socket communications.

With the RPM II SDK, only the INTREPID™ Remote Polling Module II (RPM II) is queried by the control or monitoring application. By eliminating the need for direct polling of each INTREPID device by the head-end system, the RPM II reduces time, cost and complexity associated with interface development.

Deployment of the RPM II SDK requires the purchase of an INTREPID™ Remote Polling Module II (RPM II) Controller, which handles polling of individual INTREPID™ Series II sensors and auxiliary devices.



## REMOTE POLLING MODULE II (RPM II) SYSTEM CONTROLLER

The Remote Polling Module II (RPM II) is an INTREPID™ System Controller designed to provide network-based large or multi-site facilities with simplified high-level integration (via SDK) between third-party control or monitoring systems and INTREPID™ Series II sensors and auxiliary devices.

The RPM II is a self-contained hardware module with accompanying Software Development Kit (SDK) that eliminates the need for direct polling of each INTREPID™ device by the head-end system, dramatically simplifying interface development. The RPM II serves as Pollmaster - polling all INTREPID™ Series II sensors and auxiliary devices connected to its communications port for status, and communicating this information to the third-party control or monitoring system via TCP/IP network connection.

### RPM II KEY FEATURES

- PROVIDES INTERFACE VIA SDK TO INTREPID™ SERIES II SYSTEMS
- LOCAL OR NETWORK-BASED ALARM REPORTING
- LOCAL OR REMOTE SENSOR CONFIGURATION AND MAINTENANCE
- SINGLE OR MULTI-SITE MONITORING\*
- CONNECTS UP TO 16 DEVICES
- INTUITIVE SETUP SOFTWARE

### RPM II SPECIFICATIONS

**Operating Temperature:** -40° C to 70° C (-40° F to 158°F)  
**Size:** 13.9 H x 33.7 W x 12.7 D cm (5.5 x 13.3 x 5 in)  
**Weight:** 1.36 kg (3 lbs)  
**Input Power:** 10.5 to 60 VDC  
**Current Draw:** 12 VDC: 400 mA, 24 VDC: 120 mA, 48 VDC: 100 mA  
**Ports:** RJ45 for network connection (1), USB-B (1), RS422 [2]  
**Languages:** English

\* For multi-site applications using the RPM II SDK, each site requires a unique RPM II Network System Controller.

## IPP II EXAMPLE CONFIGURATION DIAGRAM

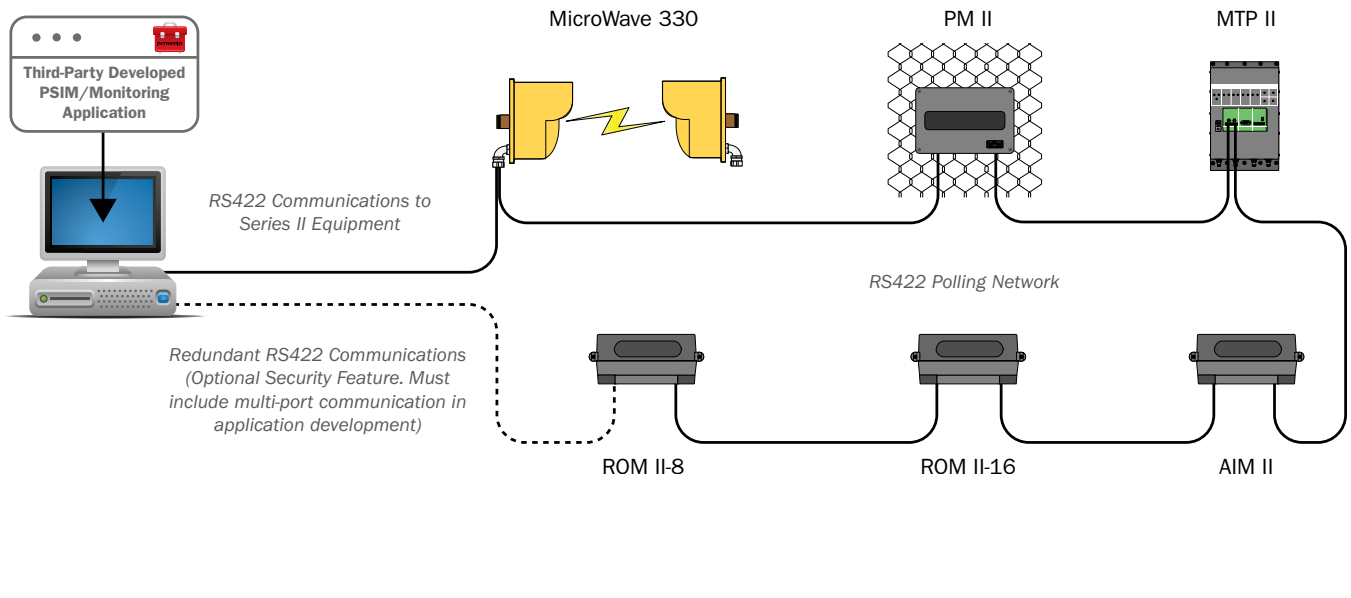

## RPM II EXAMPLE CONFIGURATION DIAGRAM

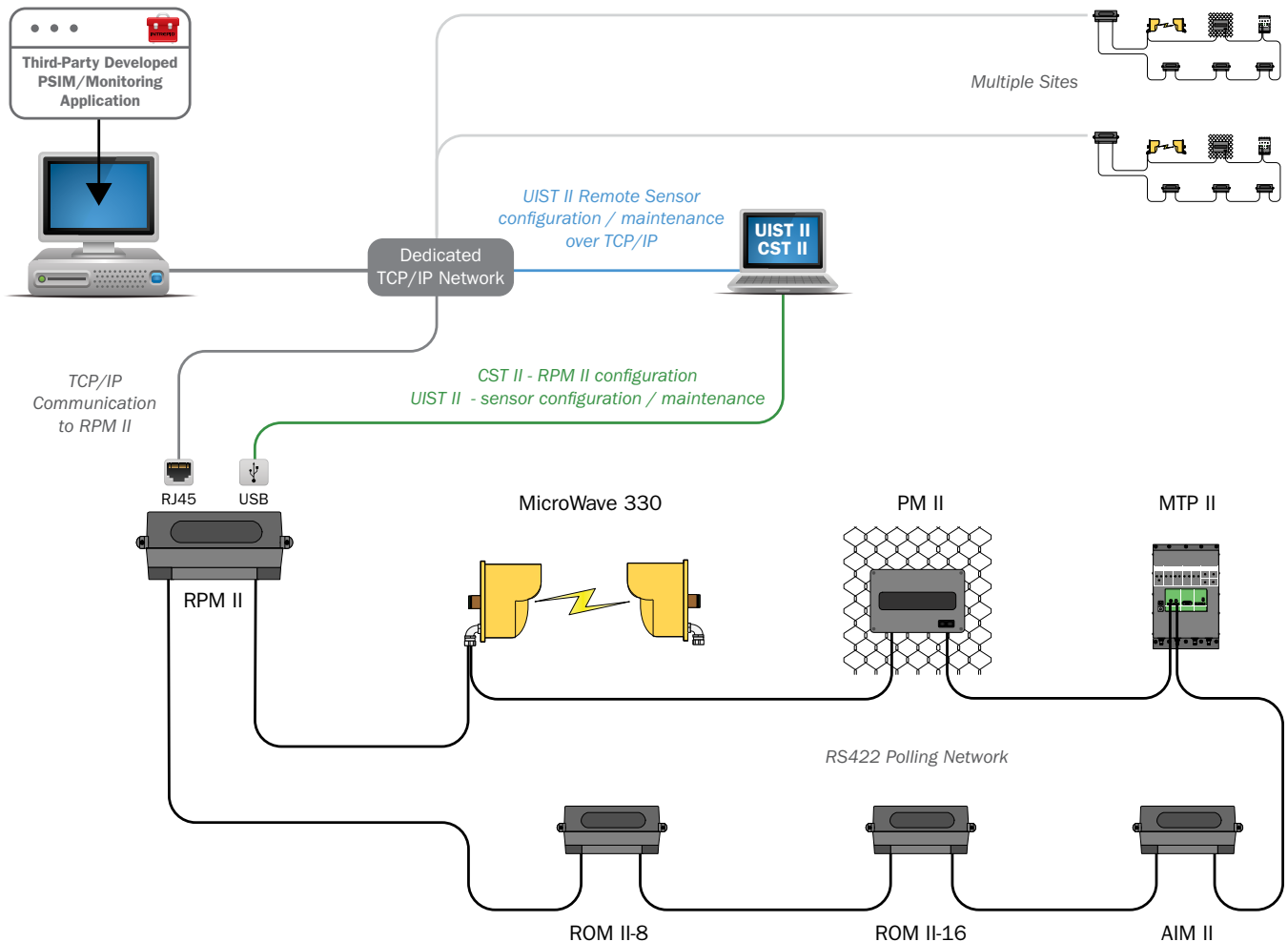

# TECHNOLOGY PARTNERS

Using our Software Development Kits (SDK), leading global providers of security management and monitoring solutions have developed custom high-level integrations to Southwest Microwave's INTREPID™ intrusion detection systems. Together, our high-performance systems protect the infrastructure and assets of many of the world's most security-sensitive sites in the critical utilities, transportation, government, military, industrial, corrections and VIP residential sectors.

Contact us at [infossd@southwestmicrowave.com](mailto:infossd@southwestmicrowave.com) for further information or to request SDK documentation.



**USA (CORPORATE HEADQUARTERS):**  
Southwest Microwave, Inc., Arizona, USA  
Telephone +1 (480) 783-0201

**EUROPEAN OFFICES:**  
Southwest Microwave Ltd., Worcestershire, UK  
Telephone +44 1386 75 15 11

**MIDDLE EAST OFFICES:**  
Southwest Microwave, Inc., Dubai, UAE  
Telephone: +971 4 371 2624